

TOSHIBA

Leading Innovation >>>



AIR TO WATER HEAT PUMP Installation Manual



Outdoor Unit

Model name:

HWS-805H-E

HWS-1105H-E

HWS-1405H-E

HWS-1105H8-E

HWS-1405H8-E

HWS-1605H8-E

HWS-1105H8R-E

HWS-1405H8R-E

HWS-1605H8R-E

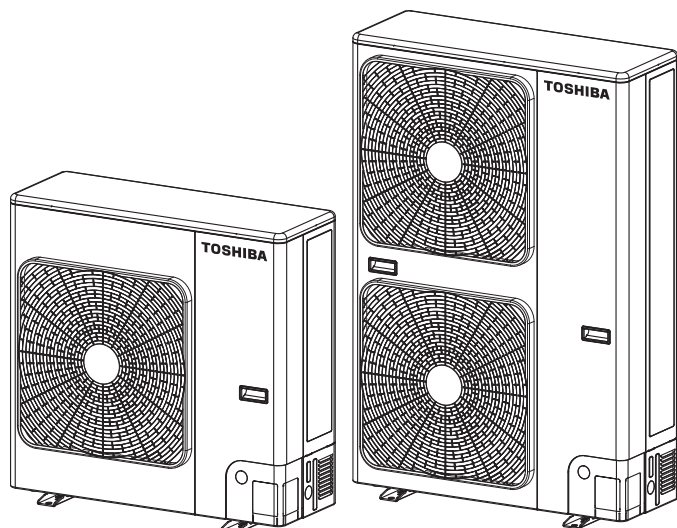

Please read this Installation Manual carefully before installing the Air to Water Heat Pump.

- This Manual describes the installation method of the outdoor unit.
- For installation of the hydro unit, follow the Installation Manual attached to the hydro unit.

Original instruction

REFRIGERANT

This Air to water heat pump uses an HFC refrigerant (R410A) in order to prevent destruction of the ozone layer.

▼ HWS-805H-E, HWS-1105H-E, HWS-1405H-E

Equipment complying with IEC 610003-12.

▼ HWS-1105H8-E, HWS-1105H8R-E HWS-1405H8-E, HWS-1405H8R-E HWS-1605H8-E, HWS-1605H8R-E

This equipment complies with IEC 61000-3-12 provided that the short-circuit power S_{sc} is greater than or equal to $S_{sc} (*1)$ at the interface point between the user's supply and the public system. It is the responsibility of the installer or user of the equipment to ensure, by consultation with the distribution network operator if necessary, that the equipment is connected only to a supply with a short-circuit power S_{sc} greater than or equal to $S_{sc} (*1)$. Furthermore, when similar equipment or other equipment which may cause harmonic current emissions are to be connected to the same interface point with this equipment, to reduce the risk of possible problems which may be caused from addition of those harmonic current emissions, it is recommended to make sure that the short-circuit power S_{sc} at the interface point is greater than the sum of the minimum S_{sc} required by all the equipment which will be connected to the interface point.

$S_{sc} (*1)$

Model	S_{sc} (MVA)
HWS-1105H8-E, HWS-1105H8R-E	0.71
HWS-1405H8-E, HWS-1405H8R-E	0.71
HWS-1605H8-E, HWS-1605H8R-E	0.71

Contents

1	Precautions for safety	5
2	Accessory parts and refrigerant	8
3	Installation of new refrigerant air to water heat pump	9
4	Installation conditions	10
5	Refrigerant piping	14
6	Air purging	17
7	Electrical work	19
8	Earthing	22
9	Finishing	22
10	Test run	22
11	Annual maintenance	22
12	Air to water heat pump operating conditions	22
13	Functions to be implemented locally	23
14	Troubleshooting	24
15	Appendix	26

■ Generic denomination: air to water heat pump

■ Definition of qualified installer or qualified service person

The air to water heat pump must be installed, maintained, repaired and removed by a qualified installer or qualified service person. When any of these jobs is to be done, ask a qualified installer or qualified service person to do them for you.

A qualified installer or qualified service person is an agent who has the qualifications and knowledge described in the table below.

Agent	Qualifications and knowledge which the agent must have
Qualified installer	<ul style="list-style-type: none"> • The qualified installer is a person who installs, maintains, relocates and removes the air to water heat pumps made by Toshiba Carrier Corporation. He or she has been trained to install, maintain, relocate and remove the air to water heat pump made by Toshiba Carrier Corporation or, alternatively, he or she has been instructed in such operations by an individual or individuals who have been trained and is thus thoroughly acquainted with the knowledge related to these operations. • The qualified installer who is allowed to do the electrical work involved in installation, relocation and removal has the qualifications pertaining to this electrical work as stipulated by the local laws and regulations, and he or she is a person who has been trained in matters relating to electrical work on the air to water heat pump made by Toshiba Carrier Corporation or, alternatively, he or she has been instructed in such matters by an individual or individuals who have been trained and is thus thoroughly acquainted with the knowledge related to this work. • The qualified installer who is allowed to do the refrigerant handling and piping work involved in installation, relocation and removal has the qualifications pertaining to this refrigerant handling and piping work as stipulated by the local laws and regulations, and he or she is a person who has been trained in matters relating to refrigerant handling and piping work on the air to water heat pump made by Toshiba Carrier Corporation or, alternatively, he or she has been instructed in such matters by an individual or individuals who have been trained and is thus thoroughly acquainted with the knowledge related to this work. • The qualified installer who is allowed to work at heights has been trained in matters relating to working at heights with the air to water heat pump made by Toshiba Carrier Corporation or, alternatively, he or she has been instructed in such matters by an individual or individuals who have been trained and is thus thoroughly acquainted with the knowledge related to this work.
Qualified service person	<ul style="list-style-type: none"> • The qualified service person is a person who installs, repairs, maintains, relocates and removes the air to water heat pump made by Toshiba Carrier Corporation. He or she has been trained to install, repair, maintain, relocate and remove the air to water heat pump made by Toshiba Carrier Corporation or, alternatively, he or she has been instructed in such operations by an individual or individuals who have been trained and is thus thoroughly acquainted with the knowledge related to these operations. • The qualified service person who is allowed to do the electrical work involved in installation, repair, relocation and removal has the qualifications pertaining to this electrical work as stipulated by the local laws and regulations, and he or she is a person who has been trained in matters relating to electrical work on the air to water heat pump made by Toshiba Carrier Corporation or, alternatively, he or she has been instructed in such matters by an individual or individuals who have been trained and is thus thoroughly acquainted with the knowledge related to this work. • The qualified service person who is allowed to do the refrigerant handling and piping work involved in installation, repair, relocation and removal has the qualifications pertaining to this refrigerant handling and piping work as stipulated by the local laws and regulations, and he or she is a person who has been trained in matters relating to refrigerant handling and piping work on the air to water heat pump made by Toshiba Carrier Corporation or, alternatively, he or she has been instructed in such matters by an individual or individuals who have been trained and is thus thoroughly acquainted with the knowledge related to this work. • The qualified service person who is allowed to work at heights has been trained in matters relating to working at heights with the air to water heat pump made by Toshiba Carrier Corporation or, alternatively, he or she has been instructed in such matters by an individual or individuals who have been trained and is thus thoroughly acquainted with the knowledge related to this work.

■ Definition of protective gear





When the air to water heat pump is to be transported, installed, maintained, repaired or removed, wear protective gloves and “safety” work clothing.

In addition to such normal protective gear, wear the protective gear described below when undertaking the special work detailed in the table below.

Failure to wear the proper protective gear is dangerous because you will be more susceptible to injury, burns, electric shocks and other injuries.

Work undertaken	Protective gear worn
All types of work	Protective gloves “Safety” working clothing
Electrical-related work	Gloves to provide protection for electricians and from heat Insulating shoes Clothing to provide protection from electric shock
Work done at heights (50 cm or more)	Helmets for use in industry
Transportation of heavy objects	Shoes with additional protective toe cap
Repair of outdoor unit	Gloves to provide protection for electricians and from heat

Warning Indications on the Air to water heat pump Unit

Warning indication	Description		
 <table border="1" style="margin-left: 10px;"> <tr> <td style="text-align: center;">WARNING</td> </tr> <tr> <td>ELECTRICAL SHOCK HAZARD Disconnect all remote electric power supplies before servicing.</td> </tr> </table>	WARNING	ELECTRICAL SHOCK HAZARD Disconnect all remote electric power supplies before servicing.	<p>WARNING ELECTRICAL SHOCK HAZARD Disconnect all remote electric power supplies before servicing.</p>
WARNING			
ELECTRICAL SHOCK HAZARD Disconnect all remote electric power supplies before servicing.			
 <table border="1" style="margin-left: 10px;"> <tr> <td style="text-align: center;">WARNING</td> </tr> <tr> <td>Moving parts. Do not operate unit with grille removed. Stop the unit before the servicing.</td> </tr> </table>	WARNING	Moving parts. Do not operate unit with grille removed. Stop the unit before the servicing.	<p>WARNING Moving parts. Do not operate unit with grille removed. Stop the unit before the servicing.</p>
WARNING			
Moving parts. Do not operate unit with grille removed. Stop the unit before the servicing.			
 <table border="1" style="margin-left: 10px;"> <tr> <td style="text-align: center;">CAUTION</td> </tr> <tr> <td>High temperature parts. You might get burned when removing this panel.</td> </tr> </table>	CAUTION	High temperature parts. You might get burned when removing this panel.	<p>CAUTION High temperature parts. You might get burned when removing this panel.</p>
CAUTION			
High temperature parts. You might get burned when removing this panel.			
 <table border="1" style="margin-left: 10px;"> <tr> <td style="text-align: center;">CAUTION</td> </tr> <tr> <td>Do not touch the aluminum fins of the unit. Doing so may result in injury.</td> </tr> </table>	CAUTION	Do not touch the aluminum fins of the unit. Doing so may result in injury.	<p>CAUTION Do not touch the aluminum fins of the unit. Doing so may result in injury.</p>
CAUTION			
Do not touch the aluminum fins of the unit. Doing so may result in injury.			
 <table border="1" style="margin-left: 10px;"> <tr> <td style="text-align: center;">CAUTION</td> </tr> <tr> <td>BURST HAZARD Open the service valves before the operation, otherwise there might be the burst.</td> </tr> </table>	CAUTION	BURST HAZARD Open the service valves before the operation, otherwise there might be the burst.	<p>CAUTION BURST HAZARD Open the service valves before the operation, otherwise there might be the burst.</p>
CAUTION			
BURST HAZARD Open the service valves before the operation, otherwise there might be the burst.			

1 Precautions for safety

- Ensure that all Local, National and International regulations are satisfied.
- Read this “Precautions for safety” carefully before Installation.
- The precautions described below include the important items regarding safety. Observe them without fail.
- After the installation work, perform a test run to check for any problem. Follow the Owner’s Manual to explain how to use and maintain the unit to the customer.
- Turn off the main power supply switch (or breaker) before the unit maintenance.
- Ask the customer to keep the Installation Manual together with the Owner’s Manual.

WARNING

- **Ask an authorized dealer or qualified installation professional to install / maintain the Air to Water Heat Pump.**
Inappropriate installation may result in water leakage, electric shock or fire.
- **Be sure to connect earth wire. (grounding work)**
Incomplete grounding cause an electric shock.
Do not connect ground wires to gas pipes, water pipes, lightning rods or ground wires for telephone wires.
- **Turn off the main power supply switch or breaker before attempting any electrical work.**
Make sure all power switches are off. Failure to do so may cause electric shock.
Use an exclusive power circuit for the Air to Water Heat Pump. Use the rated voltage.
- **Connect the system interconnection wire correctly.**
If the system interconnection wire is connected in a wrong way, electric parts may be damaged.
- **When moving the Air to Water Heat Pump for the installation into another place, be very careful not to enter any gaseous matter other than the specified refrigerant into the refrigeration cycle.**
If air or any other gas is mixed in the refrigerant, the gas pressure in the refrigeration cycle becomes abnormally high and it may resultingly causes pipe burst and injuries on persons.
- **Do not modify this unit by removing any of the safety guards or by by-passing any of the safety interlock switches.**
- **After unpacking the unit, examine it carefully if there are possible damage.**
- **Do not install in a place that might increase the vibration of the unit.**
- **To avoid personal injury (with sharp edges), be careful when handling parts.**
- **Perform installation work properly according to the Installation Manual.**
Inappropriate installation may result in water leakage, electric shock or fire.
- **When the Air to Water Heat Pump hydro unit is installed in a small room, provide appropriate measures to ensure that the concentration of refrigerant leakage occur in the room does not exceed the critical level.**
- **Tighten the flare nut with a torque wrench in the specified manner.**
Excessive tightening of the flare nut may cause a crack in the flare nut after a long period, which may result in refrigerant leakage.
- **Wear heavy gloves during the installation work to avoid injury.**
- **Install the Air to Water Heat Pump securely in a location where the base can sustain the weight adequately.**
- **Perform the specified installation work to guard against an earthquake.**
If the Air to Water Heat Pump is not installed appropriately, accidents may occur due to the falling unit.

- **If refrigerant gas has leaked during the installation work, ventilate the room immediately.**
If the leaked refrigerant gas comes in contact with fire, noxious gas may generate.
- **After the installation work, confirm that refrigerant gas does not leak.**
If refrigerant gas leaks into the room and flows near a fire source, such as a cooking range, noxious gas might generate.
- **Electrical work must be performed by a qualified electrician in accordance with the Installation Manual.**
Make sure the Air to Water Heat Pump uses a dedicated power supply.
An insufficient power supply capacity or inappropriate installation may cause fire.
- **Use the specified wires for wiring connect the terminals securely fix.**
To prevent external forces applied to the terminals from affecting the terminals.
- **When the Air to Water Heat Pump cannot cool or heat water well, contact the dealer from whom you purchased the Air to Water Heat Pump as refrigerant leakage is considered as the cause.**
In the case of repair that requires refill of refrigerant, ask service personnel about details of the repair.
The refrigerant used in the Air to Water Heat Pump is harmless.
Generally, the refrigerant does not leak. However, if the refrigerant leaks in a room and a heater or stove burner in the room catches fire, it may generate toxic gas.
When you ask service personnel for repairing refrigerant leakage, confirm that the leakage portion has been completely repaired.
- **Conform to the regulations of the local electric company when wiring the power supply.**
Inappropriate grounding may cause electric shock.
- **Do not install the Air to Water Heat Pump in a location subject to a risk of exposure to a combustible gas.**
If a combustible gas leaks, and stays around the unit, a fire may occur.
- **Install the refrigerant pipe securely during the installation work before operating the Air to Water Heat Pump.**
If the compressor is operated with the valve open and without the refrigerant pipe, the compressor sucks air and the refrigeration cycle is overpressurized, which may cause a burst or injury.
- **For the refrigerant recovery work (collection of refrigerant from the pipe to the compressor), stop the compressor before disconnecting the refrigerant pipe.**
If the refrigerant pipe is disconnected while the compressor is working with the valve open, the compressor sucks air and the refrigeration cycle is overpressurized, which may cause a burst or injury.

 **CAUTION**

New refrigerant air to water heat pump installation

- **This air to water heat pump adopts the new HFC refrigerant (R410A) which does not destroy ozone layer.**
- The characteristics of R410A refrigerant are; easy to absorb water, oxidizing membrane or oil, and its pressure is approx. 1.6 times higher than that of refrigerant R22. Accompanied with the new refrigerant, refrigerating oil has also been changed. Therefore, during installation work, be sure that water, dust, former refrigerant, or refrigerating oil does not enter the refrigerating cycle.







- To prevent charging an incorrect refrigerant and refrigerating oil, the sizes of connecting sections of charging port of the main unit and installation tools are changed from those for the conventional refrigerant.
- Accordingly the exclusive tools are required for the new refrigerant (R410A).
- For connecting pipes, use new and clean piping designed for R410A, and please care so that water or dust does not enter.

To disconnect the appliance from main power supply

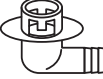
- This appliance must be connected to the main power supply by means of a switch with a contact separation of at least 3 mm.
 - The installation fuse must be used for the power supply line of this unit.
-

2 Accessory parts and refrigerant

■ Accessory parts

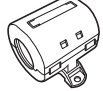
Part name	Qty	Shape	Usage
Outdoor unit installation manual	1		Hand this directly to the customer.
Drain nipple	1		
Waterproof rubber cap	5		
Protective bush	1		For protecting wires (pipe cover)
Guard material for passage part	1		For protecting passage part (pipe cover)
Energy label	2		
Product fiche	1		
Clamp filter	(1) *		For conforming to EMC standards (Used for power wire)

* HWS-1105H8-E, 1105H8R-E
HWS-1405H8-E, 1405H8R-E
HWS-1605H8-E, 1605H8R-E

3 Installation of new refrigerant air to water heat pump

- The R410A refrigerant is more susceptible to impurities such as water, oxide membranes, oils, and fats. With the adoption of the new refrigerant, the refrigerating oil has also been changed. Be careful not to let water, dust, conventional refrigerant, and/or conventional refrigerating oil enter the refrigerating cycle of the new refrigerant air to water heat pump.
- To prevent different refrigerant or refrigerating oil from becoming mixed, the sizes of the charging port of the unit and the installation tool connection sections are different from those of the conventional refrigerant. Accordingly, the following exclusive tools are required for the new refrigerant R410A.

■ Required tools / equipment and precautions for use

Prepare the tools and equipment listed in the following table before starting the installation work. Newly prepared tools and equipment must be used exclusively.

Legend

△ : Prepared newly (Use for R410A only. Do not use for refrigerant R22 or R407C etc.)

⊙ : Conventional tools / equipment are available

Tools / equipment	Use	How to use tools / equipment
Gauge manifold	Vacuuming / charging refrigerant and operation check	△ Prepared newly for R410A only
Charging hose		△ Prepared newly for R410A only
Charging cylinder	Can not be used	Unusable (Use the refrigerant charging measure instead.)
Gas leak detector	Gas leak check	△ Prepared newly
Vacuum pump	Vacuum drying	Unusable
Vacuum pump with backflow prevention function	Vacuum drying	⊙ R22 (Conventional tools)
Flare tool	Flare machining of pipes	⊙ Usable if dimensions are adjusted.
Bender	Bending pipes	⊙ R22 (Conventional tools)
Refrigerant recovery equipment	Refrigerant recovery	△ For R410A only
Torque wrench	Tightening flare nuts	△ Exclusive for Ø12.7 mm and Ø15.9 mm
Pipe cutter	Cutting pipes	⊙ R22 (Conventional tools)
Welding machine and nitrogen cylinder	Welding pipes	⊙ R22 (Conventional tools)
Refrigerant charging measure	Charging refrigerant	⊙ R22 (Conventional tools)

■ Refrigerant piping

Refrigerant (R410A)

When using the conventional piping kit

- When using the conventional piping kit with no indication of applicable refrigerant types, be sure to use it with a wall thickness of 0.8 mm for Ø6.4 mm, Ø9.5 mm, and Ø12.7 mm, and with a wall thickness of 1.0 mm for Ø15.9 mm. Do not use the conventional piping kit with a wall thickness less than these thicknesses due to insufficient pressure capacity.

When using general copper pipes

- Use general copper pipes with a wall thickness of 0.8 mm for Ø6.4 mm, Ø9.5 mm, and Ø12.7 mm, and with a wall thickness of 1.0 mm for Ø15.9 mm. Do not use any copper pipes with a wall thickness less than these thicknesses.

Flare nuts and flare machining

- The flare nuts and flare machining are different from those for the conventional refrigerant. Use the flare nuts supplied with the air to water heat pump or those for R410A.
- Before performing flare machining, carefully read "Refrigerant piping".

4 Installation conditions

■ Before installation

Be sure to prepare to the following items before installation.

Length of refrigerant pipe

Length of refrigerant pipe connected to indoor / outdoor unit	Item
5 to 30 m	Addition of refrigerant is unnecessary at the local site.

- Do not connect a refrigerant pipe that is shorter than **5 m**. This may cause a malfunction of the compressor or other devices.

■ Airtight test

- Before starting an airtight test, further tighten the spindle valves on the gas and liquid sides.
- Pressurize the pipe with nitrogen gas charged from the service port to the design pressure (4.15 MPa) to conduct an airtight test.
- After the airtight test is completed, evacuate the nitrogen gas.

Air purge

- To purge air, use a vacuum pump.
- Do not use refrigerant charged in the outdoor unit to purge air. (The air purge refrigerant is not contained in the outdoor unit.)

Electrical wiring

- Be sure to fix the power wires and hydro / outdoor connecting wires with clamps so that they do not come into contact with the cabinet, etc.

Earthing

- Proper earthing can prevent charging of electricity on the outdoor unit surface due to the presence of a high frequency in the frequency converter (inverter) of the outdoor unit, as well as prevent electric shock. If the outdoor unit is not properly earthed, you may be exposed to an electric shock.
- Be sure to connect the earth wire. (grounding work)**
Incomplete earthing can cause an electric shock. Do not connect earth wires to gas pipes, water pipes, lightning rods or earth wires for telephone wires.

Test run

Turn on the leakage breaker at least 12 hours before starting a test run to protect the compressor during startup.

■ Installation location

CAUTION

Install the outdoor unit in a location that meets the following conditions after the customer's consent is obtained.

- A well-ventilated location free from obstacles near the air intakes and air discharge
- A location that is not exposed to rain or direct sunlight
- A location that does not increase the operating noise or vibration of the outdoor unit
- A location that does not produce any drainage problems from discharged water

Do not install the outdoor unit in the following locations.

- A location with a saline atmosphere (coastal area) or one that is full of sulfide gas (hot-spring area) (Special maintenance is required.)
- A location subject to oil, vapor, oily smoke, or corrosive gases
- A location in which organic solvent is used
- A location where high-frequency equipment (including inverter equipment, private power generator, medical equipment, and communication equipment) is used (Installation in such a location may cause malfunction of the air to water heat pump, abnormal control or problems due to noise from such equipment.)
- A location in which the discharged air of the outdoor unit blows against the window of a neighboring house
- A location where the operating noise of the outdoor unit is transmitted
- When the outdoor unit is installed in an elevated position, be sure to secure its feet.
- A location in which drain water poses any problems.

1. Install the outdoor unit in a location where the discharge air is not blocked.
2. When an outdoor unit is installed in a location that is always exposed to strong winds like a coast or on the high stories of a building, secure normal fan operation by using a duct or wind shield.
3. When installing the outdoor unit in a location that is constantly exposed to strong winds such as on the upper stairs or rooftop of a building, apply the windproofing measures referred to in the following examples.

- 1) Install the unit so that its discharge port faces the wall of the building.
Keep a distance 500 mm or more between the unit and wall surface.

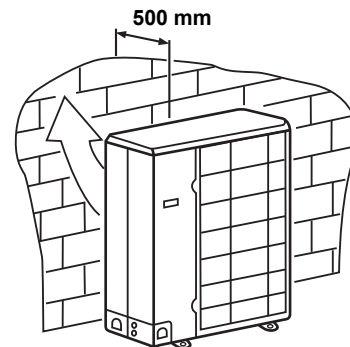

- 2) Consider the wind direction during the operational season of the Air to water Heat Pump, and install the unit so that the discharge port is set at a right angle relative to the wind direction.

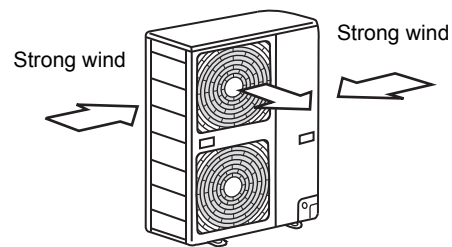

- When installing the unit in an area where snowfalls may be heavy, take steps to prevent the unit from being adversely affected by the fallen or accumulated snow.
 - Either make the foundation higher or install a stand (which is high enough to ensure that the unit will be above the fallen or accumulated snow) and place the unit on it.
 - Attach a snow shield (locally procured).

<Example>

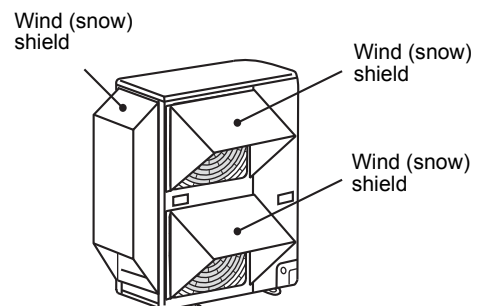

Necessary space for installation

(Unit: mm)

Obstacle at rear side

Upper side is free

1. Single unit installation

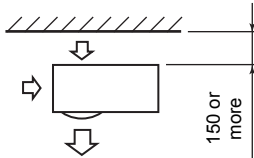

2. Obstacles on both right and left sides

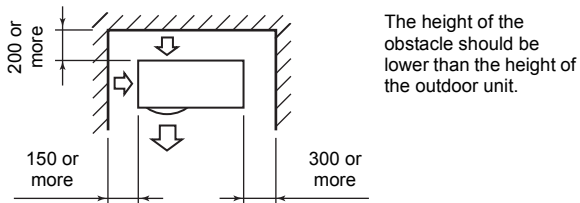

3. Serial installation of two or more units

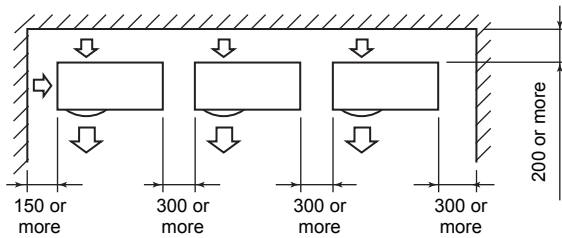

The height of the obstacle should be lower than the height of the outdoor unit.

Obstacle also above unit

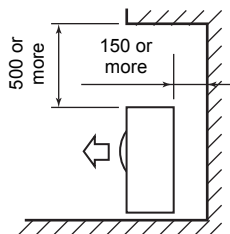

Obstacle in front

Above unit is free

1. Single unit installation

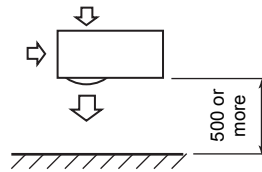

2. Serial installation of two or more units

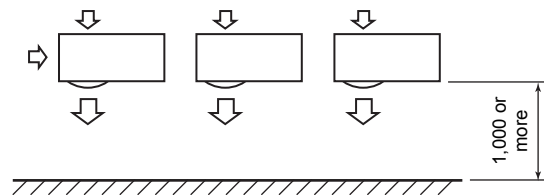

Obstacle also at the above unit

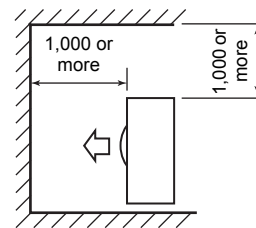

Obstacles in both front and rear of unit

Open above and to the right and left of the unit.

The height of an obstacle in both the front and rear of the unit, should be lower than the height of the outdoor unit.

Standard installation

1. Single unit installation

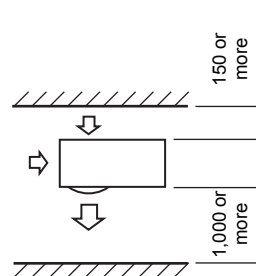

2. Serial installation of two or more units

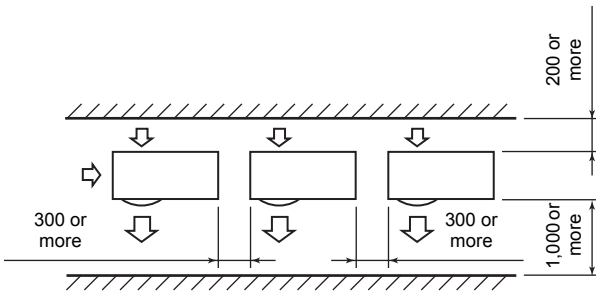

Serial installation in front and rear

Open above and to the right and left of the unit. The height of an obstacle in both the front and rear of the unit should be lower than the height of the outdoor unit.

Standard installation

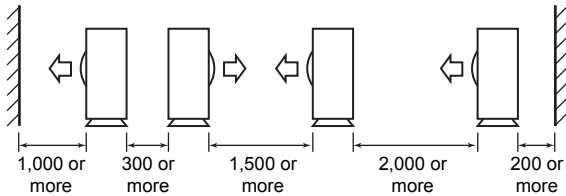

Installation of outdoor unit

- Before installation, check the strength and horizontalness of the base so that abnormal sounds do not emanate.
- According to the following base diagram, fix the base firmly with the anchor bolts.
- (Anchor bolt, nut: M10 x 4 pairs)

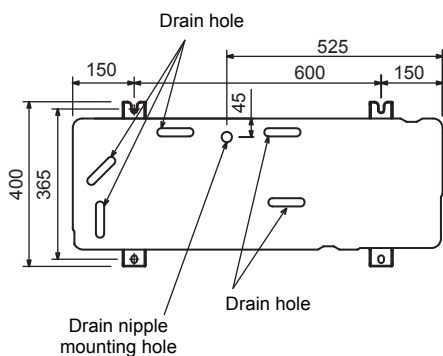

- As shown in the figure below, install the foundation and vibration-proof rubber pads to directly support the bottom surface of the fixing leg that is in contact with and underneath the bottom plate of the outdoor unit.
- * When installing the foundation for an outdoor unit with downward piping, consider the piping work.

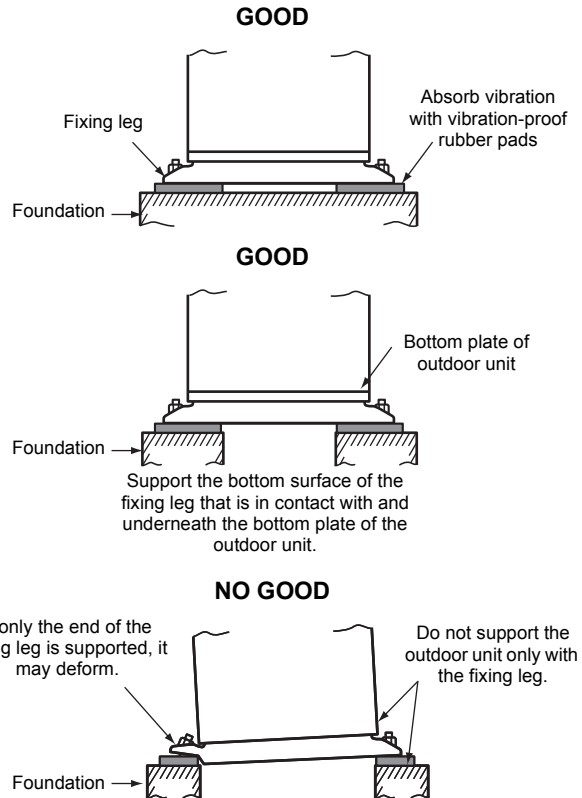

Set the out margin of the anchor bolt to 15 mm or less.

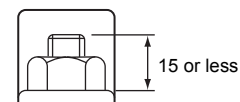

- When water is to be drained through the drain hose, attach the following drain nipple and waterproof rubber cap, and use the drain hose (Inner diam: 16 mm) sold on the market. Also seal knockout hole and the screws securely with silicone material, etc., to prevent water from leaking. Some conditions may cause dewing or dripping of water.

- When collectively draining discharged water completely, use a drain pan.

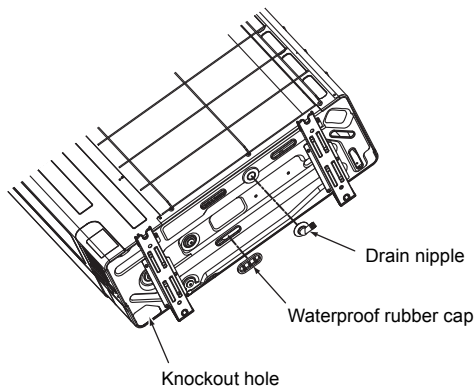
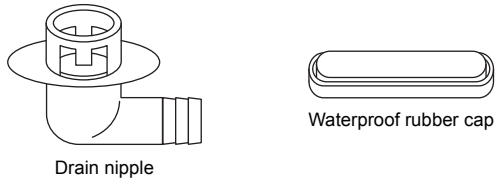

■ For reference

If a heating operation is to be continuously performed for a long time under the condition that the outdoor temperature is 0 °C or lower, draining defrosted water may be difficult due to the bottom plate freezing, resulting in trouble with the cabinet or fan.

It is recommended to procure an anti-freeze heater locally in order to safely install the air to water heat pump. (HWS-**H8R-E : Cord heater is installed)
For details, contact the dealer.

5 Refrigerant piping

■ Knockout of pipe cover

Knockout procedure

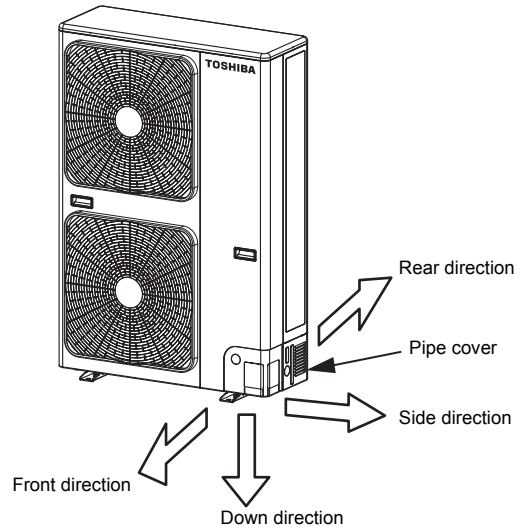

- The indoor / outdoor connecting pipes can be connected in 4 directions.
Take off the knockout part of the pipe cover through which pipes or wires will pass through the base plate.
- Detach the pipe cover and tap on the knockout section a few times with the shank of a screwdriver. A knockout hole can easily be punched.
- After punching out the knockout hole, remove burrs from the hole and then install the supplied protective bush and guard material around the passage hole to protect wires and pipes.
Be sure to attach the pipe covers after pipes have been connected. Cut the slits under the pipe covers to facilitate the installation.
After connecting the pipes, be sure to mount the pipe cover. The pipe cover is easily mounted by cutting off the slit at the lower part of the pipe cover.



* Be sure to wear heavy work gloves while working.

Optional installation parts (Locally procured)

	Parts name	Qty
A	Refrigerant piping Liquid side: Ø9.5 mm Gas side: Ø15.9 mm	One each
B	Pipe insulating material (polyethylene foam, 10 mm thick)	1
C	Putty, PVC tape	One each

Refrigerant piping connection

CAUTION

TAKE NOTE OF THESE 4 IMPORTANT POINTS BELOW FOR PIPING WORK

1. Keep dust and moisture away from inside the connecting pipes.
2. Tightly connect the connection between pipes and the unit.
3. Evacuate the air in the connecting pipes using a VACUUM PUMP.
4. Check for gas leaks at connection points.

Piping connection

Liquid side	
Outer diameter	Thickness
Ø9.5 mm	0.8 mm

Gas side	
Outer diameter	Thickness
Ø15.9 mm	1.0 mm

Flaring

1. Cut the pipe with a pipe cutter.
Be sure to remove burrs that may cause a gas leak.
2. Insert a flare nut into the pipe, and then flare the pipe. Use the flare nuts supplied with the air to water heat pump or those for R410A.
Insert a flare nut into the pipe, and flare the pipe. As the flaring sizes of R410A differ from those of refrigerant R22, the flare tools newly manufactured for R410A are recommended. However, the conventional tools can be used by adjusting the projection margin of the copper pipe.

Projection margin in flaring: B (Unit: mm)

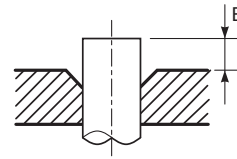

Rigid (Clutch type)

Outer diam. of copper pipe	R410A tool used	Conventional tool used
	R410A	
9.5	0 to 0.5	1.0 to 1.5
15.9		

Flaring diameter size: A (Unit: mm)

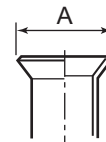

Outer diam. of copper pipe	A ⁺⁰ _{-0.4}
9.5	13.2
15.9	19.7

* In case of flaring for R410A with the conventional flare tool, pull the tool out approx. 0.5 mm more than that for R22 to adjust it to the specified flare size. The copper pipe gauge is useful for adjusting the projection margin size.

Piping necessary to change the flare nut / machining size due to pipe compression

Flare nut width: H and flare matching size: A.

Flare nut width: H

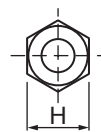

	(mm)				
Copper pipe outer dia.	Ø6.4	Ø9.5	Ø12.7	Ø15.9	Ø19.0
For R410A	17	22	26	29	36
For R22	Same as above		24	27	Same as above

Flare machining size: A

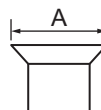

	(mm)				
Copper pipe outer dia.	Ø6.4	Ø9.5	Ø12.7	Ø15.9	Ø19.0
For R410A	9.1	13.2	16.6	19.7	24.0
For R22	9.0	13.0	16.2	19.4	23.3

Becomes a little larger for R410A

Do not apply refrigerator oil to the flare surface.

■ Tightening of connecting part

1. Align the centers of the connecting pipes and fully tighten the flare nut with your fingers. Then fix the nut with a wrench as shown in the figure and tighten it with a torque wrench.

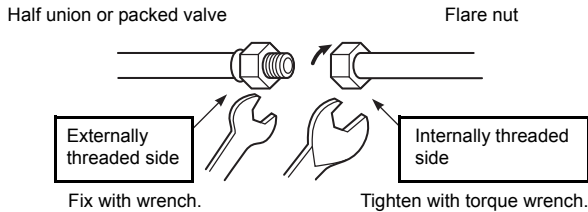

2. As shown in the figure, be sure to use two wrenches to loosen or tighten the flare nut of the valve on the gas side. If you use a single crescent, the flare nut cannot be tightened to the required tightening torque. On the other hand, use a single crescent to loosen or tighten the flare nut of the valve on the liquid side.

(Unit: N•m)

Outer dia. of copper pipe	Tightening torque
9.5 mm (diam.)	33 to 42 (3.3 to 4.2 kgf•m)
15.9 mm (diam.)	68 to 82 (6.8 to 8.2 kgf•m)

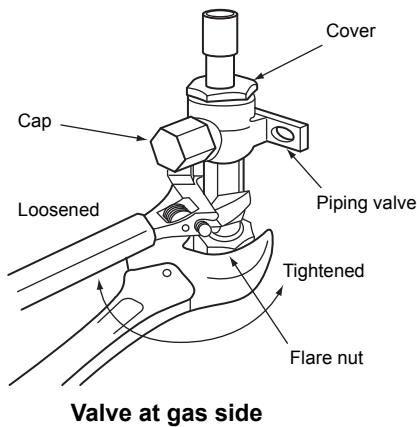

Valve at gas side

⚠ CAUTION

1. Do not put the crescent wrench on the cap or cover. The valve may break.
2. If applying excessive torque, the nut may break according to some installation conditions.

NO GOOD

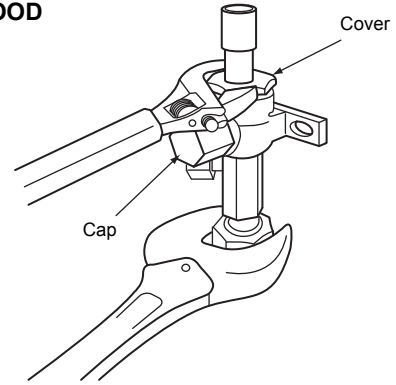

- After the installation work, be sure to check for gas leaks of the pipe connections with nitrogen.
- Pressure of R410A is higher than that of R22 (Approx. 1.6 times). Therefore, using a torque wrench, tighten the flare pipe connecting sections that connect the indoor / outdoor units at the specified tightening torque. Incomplete connections may cause not only a gas leak, but also trouble with the refrigeration cycle.

Do not apply refrigerating machine oil to the flared surface.

■ Refrigerant pipe length

Refrigeration pipe

H: max. ±30 m (above / below)

L: max. 30 m, min 5 m

30 m chargeless

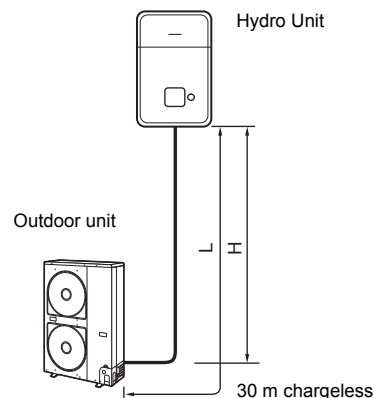

6 Air purging

■ Airtight test

Before starting an airtight test, further tighten the spindle valves on the gas side and liquid side. Pressurize the pipe with nitrogen gas charged from the service port to the design pressure (4.15 MPa) to conduct the airtight test.

After the airtight test is completed, evacuate the nitrogen gas.

■ Air purge

With respect to the preservation of the terrestrial environment, adopt "Vacuum pump" to purge air (Evacuate air in the connecting pipes) when installing the unit.

- Do not discharge the refrigerant gas to the atmosphere to preserve the terrestrial environment.
- Use a vacuum pump to discharge the air (nitrogen, etc.) that remains in the set. If air remains, the capacity may decrease.

For the vacuum pump, be sure to use one with a backflow preventer so that the oil in the pump does not backflow into the pipe of the air to water heat pump when the pump stops.

(If oil in the vacuum pump is put in an air to water heat pump including R410A, it may cause trouble with the refrigeration cycle.)

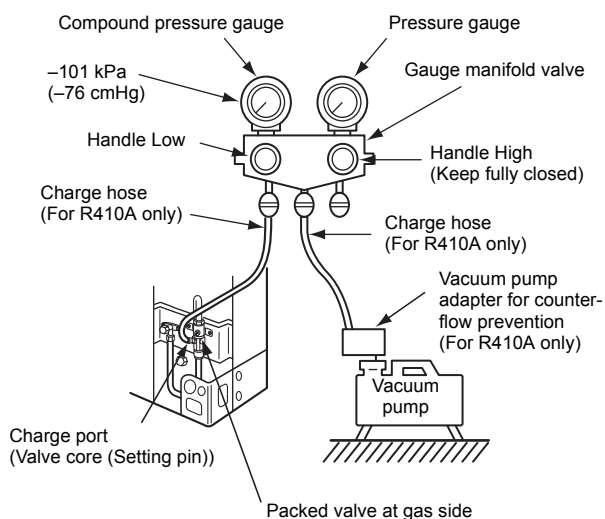

Vacuum pump

As shown in the figure, connect the charge hose after the manifold valve is closed completely.



Attach the connecting port of the charge hose with a projection to push the valve core (setting pin) to the charge port of the set.



Open Handle Low fully.



Turn ON the vacuum pump. (*1)



Loosen the flare nut of the packed valve (Gas side) a little to check that the air passes through. (*2)



Retighten the flare nut.



Execute vacuuming until the compound pressure gauge indicates -101 kPa (-76 cmHg). (*1)



Close Handle Low completely.



Turn OFF the vacuum pump.



Leave the vacuum pump as it is for 1 or 2 minutes, and check that the indicator of the compound pressure gauge does not return.



Open the valve stem or valve handle fully. (First, at liquid side, then gas side)



Disconnect the charge hose from the charge port.



Tighten the valve and caps of the charge port securely.

*1 Use the vacuum pump, vacuum pump adapter, and gauge manifold correctly referring to the manuals supplied with each tool before using them. Check that the vacuum pump oil is filled up to the specified line of the oil gauge.

*2 When air is not charged, check again whether the connecting port of the discharge hose, which has a projection to push the valve core, is firmly connected to the charge port.

■ How to open the valve

Open or close the valve.

Liquid side

Open the valve with a 4 mm hexagon wrench.

Gas side

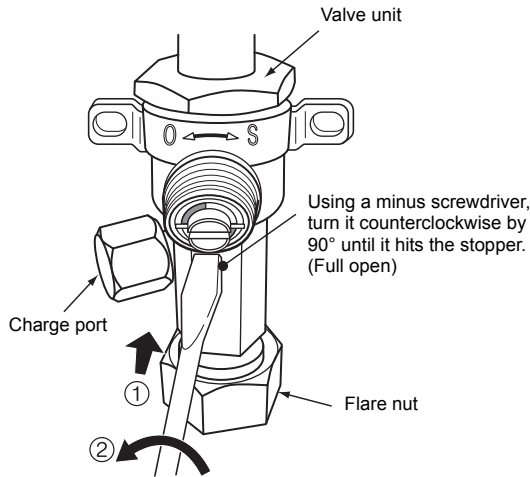

Handle position

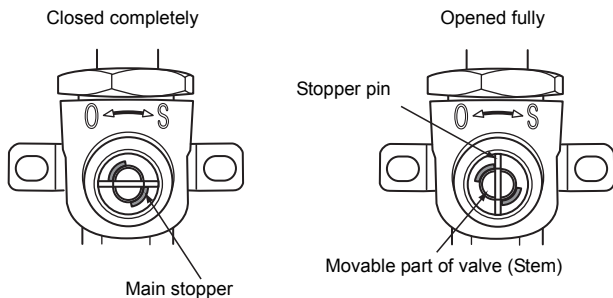

- While the valve is fully opened, after the screwdriver has reached the stopper, do not apply torque exceeding 5 N•m. Applying excessive torque may damage the valve.

Valve handling precautions

- Open the valve stem until it strikes the stopper. It is unnecessary to apply further force.
- Securely tighten the cap with a torque wrench.

Cap tightening torque

The cap with the 9.5 mm outer diameter is available in two sizes in accordance with the type of packed valve for which the cap is used. The tightening torque depends on the width across flats of the cap so check it in the table below.

Valve size	Ø9.5 mm (H22 mm)	33 to 42 N•m (3.3 to 4.2 kgf•m)
	Ø9.5 mm (H19 mm)	14 to 18 N•m (1.4 to 1.8 kgf•m)
	Ø15.9 mm	20 to 25 N•m (2.0 to 2.5 kgf•m)
Charge port		14 to 18 N•m (1.4 to 1.8 kgf•m)

■ Replenishing refrigerant

This model is a 30 m chargeless type that does not need to have its refrigerant replenished for refrigerant pipes up to 30 m.

Refrigerant replenishing procedure

1. After vacuuming the refrigerant pipe, close the valves and then charge the refrigerant while the air to water heat pump is not working.
2. When the refrigerant cannot be charged to the specified amount, charge the required amount of refrigerant from the charge port of the valve on the gas side during cooling.

Requirement for replenishing refrigerant

Replenish liquid refrigerant.

When gaseous refrigerant is replenished, the refrigerant composition varies, which disables normal operation.

Adding additional refrigerant

- The refrigerant need not be reduced for a 30 meter (or less) refrigerant pipe.

7 Electrical work

WARNING

1. **Using the specified wires, ensure that the wires are connected, and fix wires securely so that the external tension to the wires does not affect the connecting part of the terminals.**
Incomplete connection or fixation may cause a fire, etc.
2. **Be sure to connect the earth wire. (grounding work)**
Incomplete grounding may lead to electric shock.
Do not connect ground wires to gas pipes, water pipes, lightning rods or ground wires for telephone wires.
3. **The appliance shall be installed in accordance with national wiring regulations.**
Capacity shortages of the power circuit or an incomplete installation may cause an electric shock or fire.

CAUTION

- Wrong wiring may cause a burn-out of some electrical parts.
 - Be sure to use the cord clamps attached to the product.
 - Do not damage or scratch the conductive core or inner insulator of the power and inter-connecting wires when peeling them.
 - Use the power and inter-connecting wires with specified thicknesses, specified types and protective devices required.
-
- Remove the panel, and you can see electric parts on the front side.
 - A metal pipe can be installed through the hole for wiring. If the hole size does not fit the wiring pipe to be used, drill the hole again to an appropriate size.
 - Be sure to clamp the power wires and system interconnection wires with a banding band along the connecting pipe so that the wires do not touch the compressor or discharge pipe.
 - (The compressor and the discharge pipe become hot.)

Ensure all wires are secured using the cord clamps on the pipe valve fixing plate located inside the unit

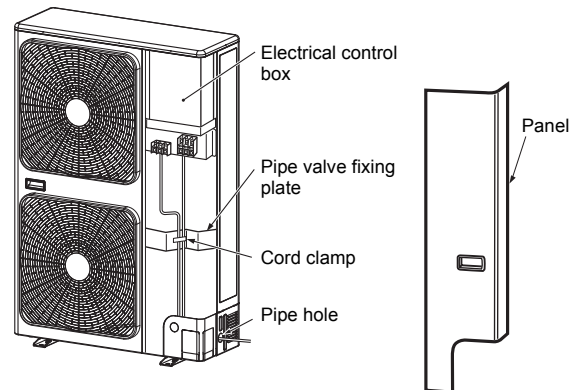

■ Wiring between hydro unit and outdoor unit

The dashed lines show on-site wiring.

Connect the system interconnection wires to the identical terminal numbers on the terminal block of each unit. Incorrect connection may cause a failure.

HWS-805H-E
HWS-1105H-E
HWS-1405H-E

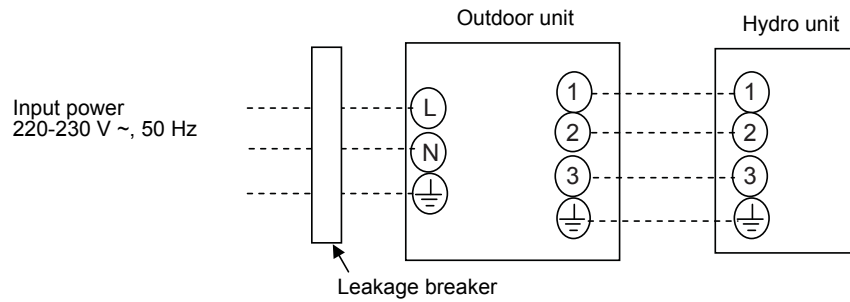

HWS-1105H8-E, H8R-E
HWS-1405H8-E, H8R-E
HWS-1605H8-E, H8R-E

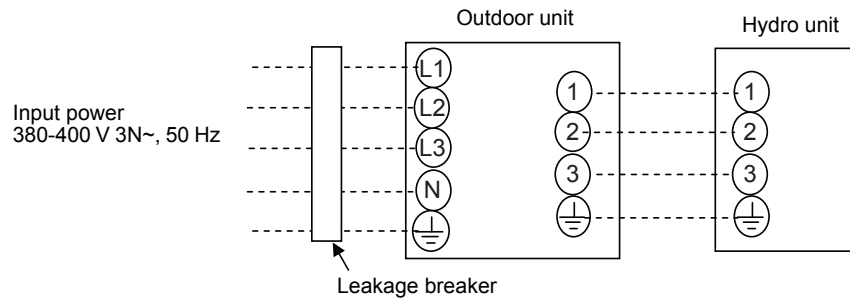

For the air to water heat pump, connect a power wire with the following specifications.

Model HWS-	805H-E	1105H-E	1405H-E	1105H8-E 1105H8R-E	1405H8-E 1405H8R-E	1605H8-E 1605H8R-E
Power supply	220-230 V ~ 50 Hz			380-400 V 3N~ 50 Hz		
Maximum running current	19.2 A	22.8 A		14.6 A		
Recommended field fuse	20 A	25 A		16 A		
Power supply wire*	3 × 2.5 mm ² or more (H07 RN-F or 60245 IEC 66)			5 × 2.5 mm ² or more (H07 RN-F or 60245 IEC 66)		
Hydro / outdoor connecting wires*	4 × 1.5 mm ² or more (H07 RN-F or 60245 IEC 66)					

* Number of wire × wire size

How to wire

1. Connect the system interconnection wire to the terminal as identified with their respective numbers on the terminal block of the Hydro and outdoor units. H07 RN-F or 60245 IEC 66 (1.5 mm² or more)
2. When connecting the system interconnection wire to the outdoor unit terminal, prevent water from coming into the outdoor unit.
3. Insulate the unsheathed cords (conductors) with electrical insulation tape. Process them so that they do not touch any electrical or metal parts.
4. For interconnecting wires, do not use a wire joined to another on the way. Use wires long enough to cover the entire length.

CAUTION

- An installation fuse must be used for the power supply line of this air to water heat pump.
 - Incorrect / incomplete wiring may lead to an electrical fire or smoke.
 - Prepare a dedicated power supply for the air to water heat pump.
 - This product can be connected to the mains power.
- Fixed wire connections:
A switch that disconnects all poles and has a contact separation of at least 3 mm must be incorporated in the fixed wiring.

▼ HWS-805H-E, HWS-1105H-E, HWS-1405H-E

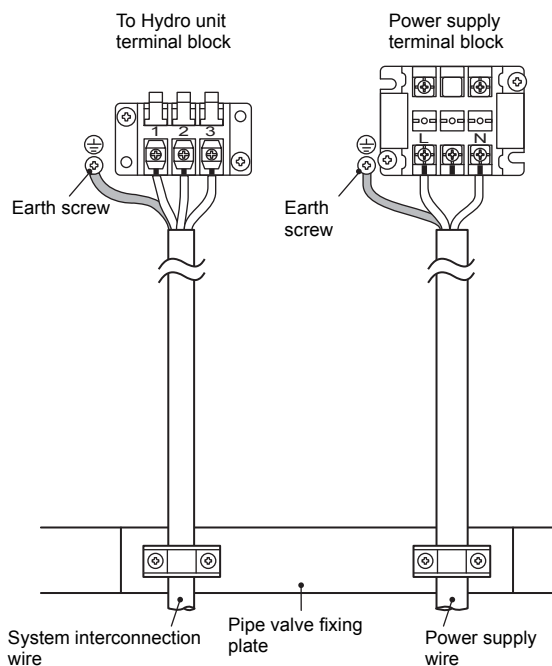

Stripping length power supply wire and system interconnection wire

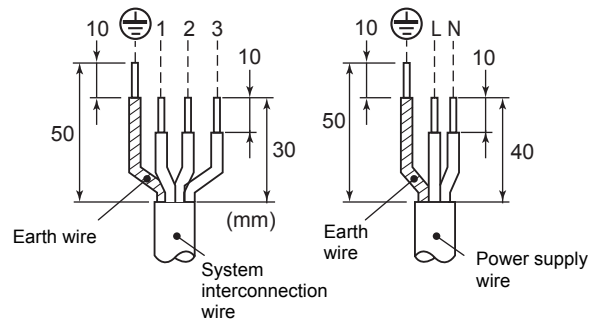

▼ HWS-1105H8-E, H8R-E
HWS-1405H8-E, H8R-E
HWS-1605H8-E, H8R-E

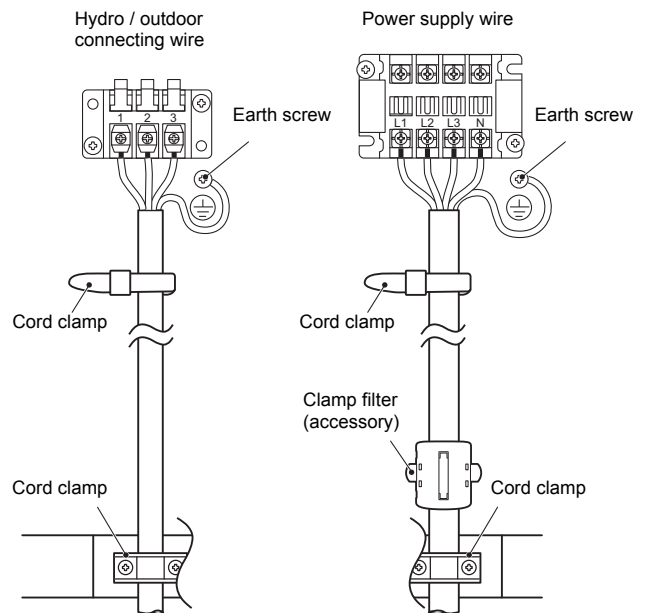

Stripping length power supply wire and system interconnection wire

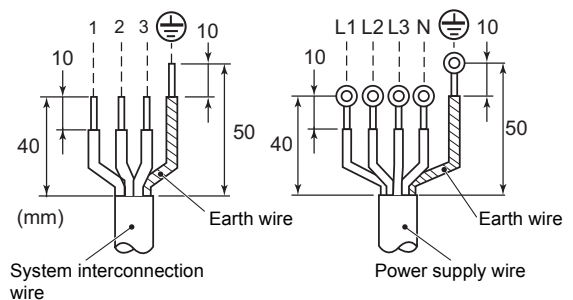

WARNING

Be sure to attach the provided clamp filter to the power supply wire in order to conform to EMC standards.

8 Earthing

Connect the earth wire properly following applicable technical standards.

Connecting the earth wire is essential to preventing electric shock and to reducing noise and electrical charges on the outdoor unit surface due to the high-frequency wave generated by the frequency converter (inverter) in the outdoor unit.

If you touch the charged outdoor unit without an earth wire, you may experience an electric shock.

9 Finishing

After the refrigerant pipe, Hydro / Outdoor connecting wires have been connected, cover them with finishing tape and clamp them to the wall with off-the-shelf support brackets or their equivalent.

Keep the power wires and Hydro / outdoor connecting wires off the valve on the gas side or pipes that have no heat insulator.

10 Test run

- Turn on the leakage breaker at least 12 hours before starting a test run to protect the compressor during startup.
- Check the following before starting a test run:
 - **That all pipes are connected securely without leaks.**
 - **That the valve is open.**
If the compressor is operated with the valve closed, the outdoor unit will become overpressurized, which may damage the compressor or other components.
If there is a leak at a connection, air can be sucked in and the internal pressure further increases, which may cause a burst or injury.
- Operate the air to water heat pump in the correct procedure as specified in the Owner's Manual.

Please refer to the Hydro unit installation manual for the detail of the test run.

11 Annual maintenance

- For an air to water heat pump system that is operated on a regular basis, cleaning and maintenance of the Hydro / outdoor units are strongly recommended.
As a general rule, if an Hydro unit is operated for about 8 hours daily, the Hydro / outdoor units will need to be cleaned at least once every 3 months. This cleaning and maintenance should be carried out by a qualified service person.
Failure to clean the Hydro / outdoor units regularly will result in poor performance, icing, water leaking and even compressor failure.

12 Air to water heat pump operating conditions

For proper performance, operate the air to water heat pump under the following temperature conditions:

Cooling operation	10 °C to 43 °C
Heating operation	-20 °C to 25 °C
Hot water operation	-20 °C to 43 °C*

If air to water heat pump is used outside of the above conditions, safety protection may work.

* Heater operation in more than 35 °C

13 Functions to be implemented locally

■ Handling existing pipe

When using the existing pipe, carefully check for the following:

- Wall thickness (within the specified range)
- Scratches and dents
- Water, oil, dirt, or dust in the pipe
- Flare looseness and leakage from welds
- Deterioration of copper pipe and heat insulator

Cautions for using existing pipe

- Do not reuse a flare nut to prevent gas leaks. Replace it with the supplied flare nut and then process it to a flare.
- Blow nitrogen gas or use an appropriate means to keep the inside of the pipe clean. If discolored oil or much residue is discharged, wash the pipe.
- Check welds, if any, on the pipe for gas leaks.

When the pipe corresponds to any of the following, do not use it. Install a new pipe instead.

- The pipe has been opened (disconnected from Hydro unit or outdoor unit) for a long period.
- The pipe has been connected to an outdoor unit that does not use refrigerant R22, R410A or R407C.
- The existing pipe must have a wall thickness equal to or larger than the following thicknesses.

Reference outside diameter (mm)	Wall thickness (mm)
Ø9.5	0.8
Ø15.9	1.0
Ø19.0	1.0

- Do not use any pipe with a wall thickness less than these thicknesses due to insufficient pressure capacity.

■ Recovering refrigerant

- Use refrigerant recovery switch SW801 on the P.C. board of the outdoor unit to recover refrigerant when the Hydro or outdoor unit is moved.
- Before recovering the refrigerant in the existing system, perform a cooling operation for at least 30 minutes.

Procedure

1. Drain off the water in the Hydro unit or turn on the water pump manually. (See operation check mode)
2. Turn on the power of the air to water heat pump.
3. Set SW804 on the P.C. board of the outdoor unit to all OFF, and then press SW801 for 1 second or more. The air to water heat pump enters the forced cooling mode for up to 10 minutes. Operate or handle the valve to recover refrigerant during this time period.
4. Upon completion of refrigerant recovery, close the valve and press SW801 for at least 1 second to stop operation.
5. Turn off the power.

Operation check mode

(1) Preparation

1. Turn all of the remote controllers "OFF" for the hot water supply and heating.
2. Turn off the hydro unit and the outdoor unit.
3. Remove the front panel of the hydro unit.
4. Set SW06_2 "ON".

(2) Operation check

1. Turn on the hydro unit and the outdoor unit.
2. Rotate switch DIP SW01 to position "1" and press tactile switch SW07 for 5 sec. or longer.
3. Rotating the rotary SW01 to position "16". The pump P1 will start.
4. Set the DIP SW06_02 "OFF" to finish.

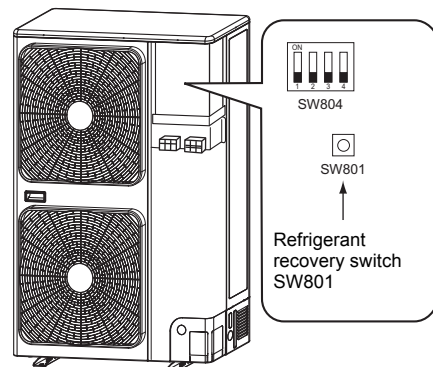

DANGER

Be careful of electric shock because the P.C. board has an electrical current running through it.

14 Troubleshooting

You can perform fault diagnosis of the outdoor unit with the LEDs on the P.C. board of the outdoor unit in addition to using the check codes displayed on the wired remote controller of the indoor unit.

Use the LEDs and check codes for various checks. Details of the check codes displayed on the wired remote controller of the indoor unit are described in the Installation Manual of the Hydro unit.

Verifying current abnormal status

1. Check that DIP switch SW803 is set to OFF.
2. Jot down the states of LED800 to LED804. (Display mode 1)
3. Press SW800 for at least 1 second. The LED status changes to display mode 2.
4. Check the code whose display mode 1 equals the LED states jotted down and display mode 2 equals the current flashing status of LED800 to LED804 from the following table to identify the cause.

Verifying an abnormal state in the past although the abnormal state no longer occurs

1. Set bit 1 of DIP switch SW803 to ON.
2. Jot down the states of LED800 to LED804. (Display mode 1)
3. Press SW800 for at least 1 second. The LED status changes to display mode 2.
4. Find an error whose display mode 1 equals the LED states jotted down and display mode 2 equals the current flashing states of LED800 to LED804 from the following table to identify the error.
 - An outside **air temperature (TO) sensor error** can be checked only while it occurs.

No.	Cause	Display mode 1					Display mode 2				
		D800	D801	D802	D803	D804	D800	D801	D802	D803	D804
1	Normal	●	●	●	●	●	●	●	●	●	●
2	Discharge (TD) sensor error	○	○	●	●	○	●	●	◎	●	●
3	Heat exchanger (TE) sensor error	○	○	●	●	○	●	◎	◎	●	●
4	Heat exchanger (TL) sensor error	○	○	●	●	○	◎	◎	◎	●	●
5	Outside air temperature (TO) sensor error	○	○	●	●	○	●	●	●	◎	●
6	Suction (TS) sensor error	○	○	●	●	○	●	●	◎	◎	●
7	Heat sink (TH) sensor error	○	○	●	●	○	◎	●	◎	◎	●
8	Outdoor temperature sensor (TE/TS) connection error	○	○	●	●	○	◎	◎	◎	◎	●
9	Outdoor EEPROM error	○	○	●	●	○	◎	◎	◎	◎	◎
10	Compressor breakdown	●	●	○	●	○	◎	●	●	●	●
11	Compressor lock	●	●	○	●	○	●	◎	●	●	●
12	Current detection circuit error	●	●	○	●	○	◎	◎	●	●	●
13	Thermostat for compressor activated	●	●	○	●	○	●	●	◎	●	●
14	Model data not set (on the service P.C. board)	●	○	○	●	○	●	◎	●	◎	●
15	MCU-MCU communication error	●	○	○	●	○	◎	●	◎	◎	◎
16	Discharge temperature error	○	○	○	●	○	◎	◎	●	●	●
17	Abnormal power (open phase detected or abnormal voltage)	○	○	○	●	○	◎	●	◎	●	●
18	Heat sink overheat	○	○	○	●	○	◎	◎	◎	●	●
19	Gas leak detected	○	○	○	●	○	◎	◎	◎	◎	●
20	4-way valve reverse error	○	○	○	●	○	◎	◎	●	●	◎

No.	Cause	Display mode 1					Display mode 2				
		D800	D801	D802	D803	D804	D800	D801	D802	D803	D804
21	High pressure release operation	○	○	○	●	○	●	●	◎	●	◎
22	Outdoor fan motor error	○	○	○	●	○	●	◎	◎	●	◎
23	Compressor driver short-circuit protection	○	○	○	●	○	●	◎	●	◎	◎
24	Position detection circuit error in one-line display	○	○	○	●	○	◎	●	◎	◎	◎
25	High pressure SW error	○	○	○	●	○	●	●	◎	●	●

(●: OFF ○: ON ◎: Flashing)

* The LEDs and DIP switches are located on the lower left of the P.C. board of the outdoor unit.

▼ HWS-805H-E, HWS-1105H-E, HWS-1405H-E

* The LEDs and DIP switches are located at the lower left of the P.C. board of the outdoor unit.

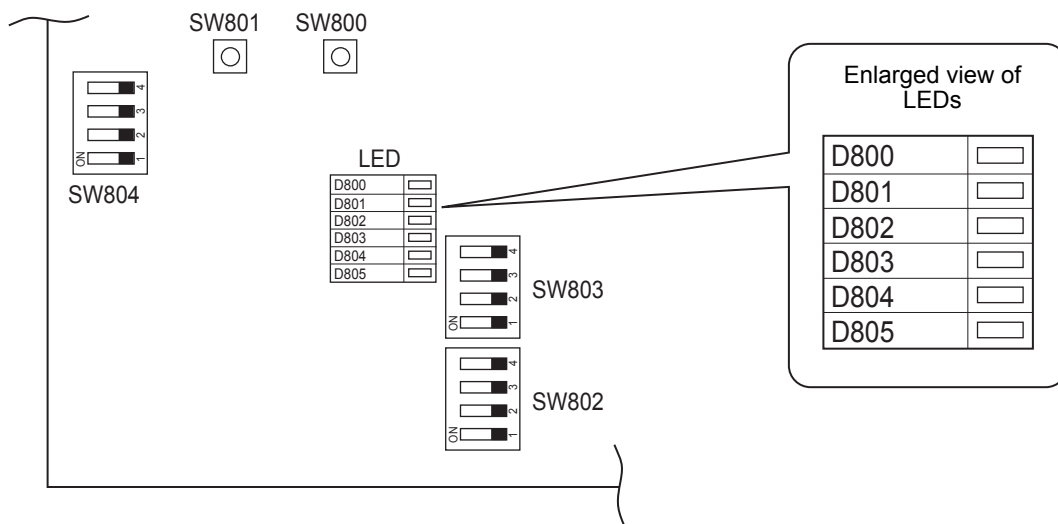

▼ HWS-1105H8-E, H8R-E
HWS-1405H8-E, H8R-E
HWS-1605H8-E, H8R-E

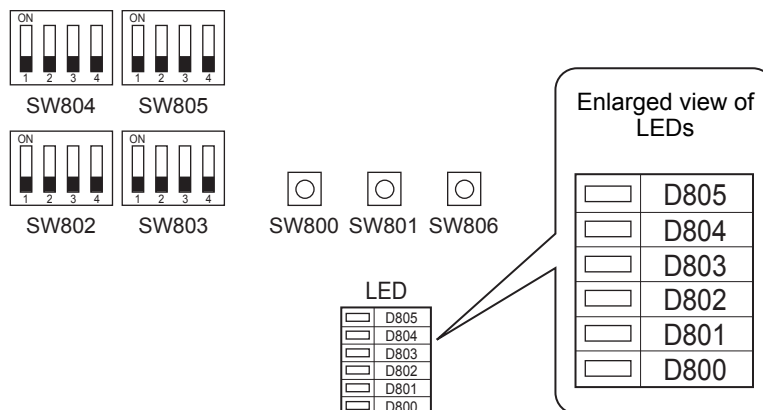

15 Appendix

■ Work instructions

The existing R22 and R407C piping can be reused for our digital inverter R410A product installations.

WARNING

Confirming the existence of scratches or dents on the existing pipes and confirming the reliability of the pipe strength are conventionally referred to the local site. If the specified conditions can be cleared, it is possible to update existing R22 and R407C pipes to those for R410A models.

Basic conditions needed to reuse existing pipes

Check and observe the presence of three conditions in the refrigerant piping works.

1. **Dry** (There is no moisture inside of the pipes.)
2. **Clean** (There is no dust inside of the pipes.)
3. **Tight** (There are no refrigerant leaks.)

Restrictions for use of existing pipes

In the following cases, the existing pipes should not be reused as they are. Clean the existing pipes or exchange them with new pipes.

1. When a scratch or dent is heavy, be sure to use new pipes for the refrigerant piping works.
2. When the existing pipe thickness is thinner than the specified "Pipe diameter and thickness," be sure to use new pipes for the refrigerant piping works.
 - The operating pressure of R410A is high (1.6 times that of R22 and R407C). If there is a scratch or dent on the pipe or a thinner pipe is used, the pressure strength may be inadequate, which may cause the pipe to break in the worst case.

* Pipe diameter and thickness (mm)

Pipe outer diameter	Ø6.4	Ø9.5	Ø12.7	Ø15.9	Ø19.0	
Thickness	R410A	0.8	0.8	0.8	1.0	1.0

- In case the pipe diameter is Ø12.7 mm or less and the thickness is 0.8 mm, be sure to use new pipes for the refrigerant piping works.
3. When the outdoor unit was left with the pipes disconnected, or the gas leaked from the pipes and the pipes were not repaired and refilled.
 - There is the possibility of rain water or air, including moisture, entering the pipe.

4. When refrigerant cannot be recovered using a refrigerant recovery unit.
 - There is the possibility that a large quantity of dirty oil or moisture remains inside the pipes.
5. When a commercially available dryer is attached to the existing pipes.
 - There is the possibility that copper green rust has been generated.
6. When the existing air to water heat pump is removed after refrigerant has been recovered.
 - Check if the oil is judged to be clearly different from normal oil.
 - The refrigerator oil is copper rust green in color: There is the possibility that moisture has mixed with the oil and rust has been generated inside the pipe.
 - There is discolored oil, a large quantity of residue, or a bad smell.
 - A large quantity of shiny metal dust or other wear residue can be seen in the refrigerant oil.
7. When the air to water heat pump has a history of the compressor failing and being replaced.
 - When discolored oil, a large quantity of residue, shiny metal dust, or other wear residue or mixture of foreign matter is observed, trouble will occur.
8. When temporary installation and removal of the air to water heat pump are repeated such as when leased etc.
9. If the type of refrigerator oil of the existing air to water heat pump is other than the following oil (Mineral oil), Suniso, Freol-S, MS (Synthetic oil), alkyl benzene (HAB, Barrel-freeze), ester series, PVE only of ether series.
 - The winding-insulation of the compressor may deteriorate.

NOTE

The above descriptions are results have been confirmed by our company and represent our views on our air to water heat pump, but do not guarantee the use of the existing pipes of air to water heat pump that have adopted R410A in other companies.

Curing of pipes

When removing and opening the Hydro or outdoor unit for a long time, cure the pipes as follows:

- Otherwise rust may be generated when moisture or foreign matter due to condensation enters the pipes.
- The rust cannot be removed by cleaning, and new pipes are necessary.

Placement location	Term	Curing manner
Outdoors	1 month or more	Pinching
	Less than 1 month	Pinching or taping
Hydro	Every time	

Contains fluorinated greenhouse gases	
Chemical Name of Gas	R410A
Global Warming Potential (GWP) of Gas	2 088

CAUTION

1. Stick the enclosed refrigerant label adjacent to the service ports for charging or recovering location and where possible adjacent to existing nameplates or product information label.
2. Clearly write the charged refrigerant quantity on the refrigerant label using indelible ink. Then, place the included transparent protective sheet over the label to prevent the writing from rubbing off.
3. Prevent emission of the contained fluorinated greenhouse gas. Ensure that the fluorinated greenhouse gas is never vented to the atmosphere during installation, service or disposal. When any leakage of the contained fluorinated greenhouse gas is detected, the leak shall be stopped and repaired as soon as possible.
4. Only qualified service personnel are allowed to access and service this product.
5. Any handling of the fluorinated greenhouse gas in this product, such as when moving the product or recharging the gas, shall comply under (EC) Regulation No. 517/2014 on certain fluorinated greenhouse gases and any relevant local legislation.
6. Periodical inspections for refrigerant leaks may be required depending on European or local legislation.
7. Contact dealers, installers, etc., for any questions.

