

Нипели месингови TIEMME

Serie **1552**



Технически характеристики

Максимална температура: 200°C
 Минимална температура: -20°C
 Максимално работно налягане: 30 bar
 Резба: външна UNI ISO 228

Описание

Тяло

Материал

Месинг CW617N - EN12164
 Месинг CW617N - EN12165

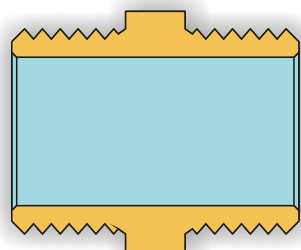
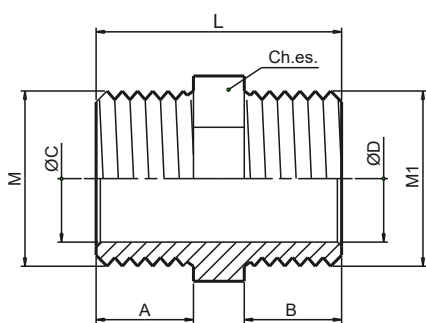

M	M1	CODICE CODE	CODICE CODE	L	A	B	ØC	ØD	Ch.es.	MATERIALE MATERIAL
1/4"	1/4"	1552G000202	150 0354	22,5	8,5	9	8,2	8,0	14	CW617N
3/8"	1/4"	1552G000302	150 0306	23,0	10	9	12,0	8,0	17	CW617N
3/8"	3/8"	1552G000303	150 0218	24,0	10	10	12,0	12,0	17	CW617N
1/2"	1/4"	1552G000402	150 0395	24,5	11,5	9	15,0	8,0	21	CW617N
1/2"	3/8"	1552G000403	150 0074	23,5	10,5	9	15,0	12,0	21	CW617N
1/2"	1/2"	1552G000404	150 0002	25,0	10,5	10,5	15,0	15,0	21	CW617N
3/4"	1/2"	1552G000504	150 0012	27,0	11,5	10,5	20,0	15,0	27	CW617N
3/4"	3/4"	1552G000505	150 0008	28,0	11,5	11,5	20,5	20,5	27	CW617N
1"	1/2"	1552G000604	150 0089	33,0	15	11,5	25,5	15,0	34	CW617N
1"	3/4"	1552G000605	150 0022	29,5	13	11,5	25,5	20,5	34	CW617N
1"	1"	1552G000606	150 0001	36,5	15	15	25,5	25,5	34	CW617N
1"1/4	1"	1552G000706	150 0044	40,0	16	15	32,0	25,5	42	CW617N
1"1/4	1"1/4	1552G000707	150 0025	41,5	16	16	34,0	34,0	46	CW617N
1"1/2	1"1/4	1552G000807	150 0097	45,0	17	16	39,0	32,0	48	CW617N
1"1/2	1"1/2	1552G000808	150 0088	46,0	17	17	39,0	39,0	48	CW617N
2"	1"1/2	1552G000908	150 0164	52,0	21	17	50,0	39,0	60	CW617N
2"	2"	1552G000909	150 0081	56,0	21	21	50,0	50,0	60	CW617N
2"1/2	1"1/2	1552G001008	150 0486	61,0	27	20	63,0	39,0	Ott.76	CW617N
2"1/2	2"1/2	1552G001010	150 0279	68,0	27	27	63,0	63,0	Ott.76	CW617N
3"	3"	1552G001111	150 0375	75,0	30	30	74,0	74,0	Ott.89	CW617N
4"	4"	1552G001212	150 0487	90,0	36	36	98,0	98,0	Ott.115	CW617N