

Тройници редуktivни месингови TIEMME

Serie **1570**



Технически характеристики

Максимална температура: 200°C
 Минимална температура: -20°C
 Максимално работно налягане: 30 bar
 Резба: вътрешна UNI ISO 228

Описание

Тяло

Материал

Месинг CW617N - EN12165

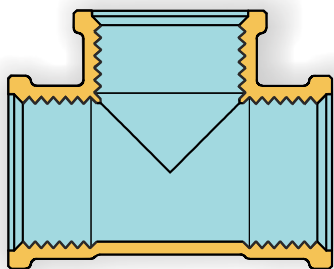
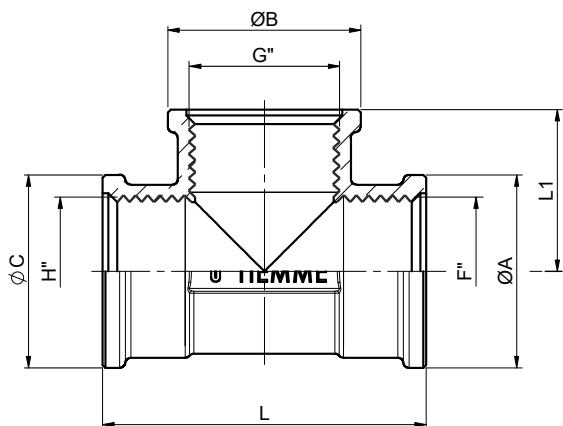

Nr.	Dimensione F"XG"xH"	L	L1	ØA	ØB	ØC
1500275	3/8"X3/8"X3/8"	43	21,5	23	23	23
1500533	1/2"X3/8"X1/2"	47	23,5	27	27	27
1500003	1/2"X1/2"X1/2"	47	23,5	27	27	27
1500544	3/4"X3/8"X3/4"	56	27	35	28,5	35
1500049	3/4"X1/2"X3/4"	56	27	35	28,5	35
1500009	3/4"X3/4"X3/4"	57	28,5	33	33	33
1500037	1"X1/2"X1"	56	29,5	42	28,5	42
1500087	1"X3/4"X1"	61	30	42	35	42
1500005	1"X1"X1"	72	36	40	40	40
1500441	1"1/4X1/2"X1"1/4	85	38,5	51	26	51
1500446	1"1/4X3/4"X1"1/4	85	38,5	51	31,5	51
1500719	1"1/4X1"X1"1/4	85	38,5	51	38	51
1500029	1"1/4X1"1/4X1"1/4	85	42,5	51	51	51
1500078	1"1/2X1"1/2X1"1/2	95	47,5	58	58	58
1500120	2"X2"X2"	110	55	70	70	70